



# Instruction Manual

## The QuickSpin™

Model Series: 3001 (000)



**GOLD MEDAL® PRODUCTS CO.**

10700 Medallion Drive, Cincinnati, Ohio 45241-4807 USA



# Table of Contents

**SAFETY PRECAUTIONS ..... 3**

**INSTALLATION INSTRUCTIONS ..... 5**

    Inspection of Shipment ..... 5

    Manual ..... 5

    Model Description ..... 5

    Items Included with this Unit ..... 5

    Setup for Use ..... 6

    Electrical Requirements ..... 7

    Before You Plug In Machine ..... 7

**OPERATING INSTRUCTIONS ..... 8**

    Controls and Their Functions ..... 8

**Operating Instructions ..... 9**

        To Make Floss ..... 9

        Standby Mode—QuickCool ..... 9

**Shut Down Procedure/ Care and Cleaning ..... 10**

        Shutdown and Clean Head ..... 10

        Clean Unit Cabinet ..... 11

**Troubleshooting ..... 11**

**—THE FOLLOWING SECTIONS ARE FOR QUALIFIED SERVICE PERSONNEL ONLY— ..... 13**

**MAINTENANCE INSTRUCTIONS ..... 13**

**Parts Installation ..... 14**

        Remove/Install Top Cover ..... 14

        Open/Close Control Panel – Access the Fuse ..... 14

        Replace the Belt ..... 15

        Replace Motor/Capacitor ..... 16

        Replace the Spinner Head and Axes ..... 17

**ORDERING SPARE PARTS ..... 19**

    Unit Exterior View ..... 19



    Interior View ..... 20



**Wiring Diagram ..... 21**

**WARRANTY ..... 23**







# SAFETY PRECAUTIONS

	 <b>DANGER</b>
	<p>Machine must be properly grounded to prevent electrical shock to personnel. Failure to do so could result in serious injury, or death. Make sure all machine switches are in the OFF position before plugging the equipment into the receptacle. Keep cord and plug off the ground and away from moisture. Always unplug the equipment before cleaning or servicing. <b>DO NOT</b> immerse any part of this equipment in water. <b>DO NOT</b> use a water jet or excessive water when cleaning.</p> <p style="text-align: right; font-size: small;">008_012221</p>

	 <b>DANGER</b>
	<p>Improper installation, adjustment, alteration, service, or maintenance can cause property damage, injury, or death. Any alterations to this equipment will void the warranty and may cause a dangerous condition. This appliance is not intended to be operated by means of an external timer or separate remote-control system. <b>NEVER</b> make alterations to this equipment. Read the Installation, Operating, and Maintenance Instructions thoroughly before installing, servicing, or operating this equipment.</p> <p style="text-align: right; font-size: small;">014_020416</p>



	 <b>WARNING</b>
	<p>Floss head rotates at high speeds. Operator <b>MUST</b> keep hands and face clear of the floss head to avoid injury. Operator must wear eye protection. Keep all spectators at a reasonable distance, and use a Floss Bubble for added customer protection. Keep all foreign objects out of floss head.</p> <p style="text-align: right; font-size: small;">015_020124</p>

	 <b>WARNING</b>
	<p>Burn Hazard. <b>DO NOT</b> touch spinner head. Allow to cool before cleaning or servicing. Avoid contact with molten sugar.</p> <p style="text-align: right; font-size: small;">006_092414</p>

	 <b>WARNING</b>
	<p><b>ALWAYS</b> wear safety glasses when servicing this equipment.</p> <p style="text-align: right; font-size: small;">010_010914</p>

	 <b>WARNING</b>
	<p>No user serviceable parts inside. Refer servicing to qualified service personnel.</p> <p style="text-align: right; font-size: small;">011_051514</p>

	 <b>WARNING</b>
	<p>Read and understand operator's manual and all other safety instructions before using this equipment. To order copies of the operator's manual go to <a href="http://gmpopcorn.com">gmpopcorn.com</a> or write to Gold Medal Products Co., 10700 Medallion Drive, Cincinnati, OH 45241 USA 1-(800)-543-0862</p> <p style="text-align: right; font-size: small;">022_060215</p>

	<p style="text-align: center;"><b>⚠ WARNING</b></p> <p>DO NOT allow direct contact of this equipment by the public when used in food service locations. Only personnel trained and experienced in the equipment operation may operate this equipment. Carefully read all instructions before operation.</p> <p style="text-align: right;">012_010914</p>
	<p style="text-align: center;"><b>⚠ WARNING</b></p> <p>This machine is NOT to be operated by minors.</p> <p style="text-align: right;">007_010914</p>
	<p style="text-align: center;"><b>⚠ CAUTION</b></p> <p>If the supply cord is damaged, it must be replaced by a special cord or assembly available from Gold Medal Products Co. or its service agent.</p> <p style="text-align: right;">038_062714</p>

This appliance is not intended for use by persons (including children) with reduced physical, sensory or mental capabilities, or lack of experience and knowledge, unless they have been given supervision or instruction concerning use of the appliance by a person responsible for their safety.

DO NOT install equipment in an area where a water jet is used.

Unit to be installed in locations where ambient temperatures are between a minimum of 5°C (41°F) and a maximum of 55°C (131°F).

Unit to be installed in locations where it can be overseen by trained personnel.

Install unit on a level surface.

Unit is for cotton candy.

**Note:** Improvements are always being made to Gold Medal's equipment. This information may not be the latest available for your purposes. It is critical that you call Gold Medal's Technical Service Department at 1-800-543-0862 for any questions about your machine operations, replacement parts, or any service questions. (Gold Medal Products Co. does not assume any liability for injury due to careless handling and/or reckless operation of this equipment.) General images may be used in manual for reference only.

# INSTALLATION INSTRUCTIONS

## Inspection of Shipment

After unpacking, check thoroughly for any damage which may have occurred in transit. Claims should be filed immediately with the transportation company. The warranty does not cover damage that occurs in transit, or damage caused by abuse, or consequential damage due to the operation of this machine, since it is beyond our control (reference warranty in back of manual).

## Manual

Read and understand the operator's manual and all other safety instructions before using this equipment. To order copies of the operator's manual go to [gmpopcorn.com](http://gmpopcorn.com) or write to Gold Medal Products Co., 10700 Medallion Drive, Cincinnati, OH 45241 USA 1-(800)-543-0862.

## Model Description

**3001 (000):** The QuickSpin is a single serve cotton candy machine with a stainless-steel floss pan and clear floss bubble.

## Items Included with this Unit

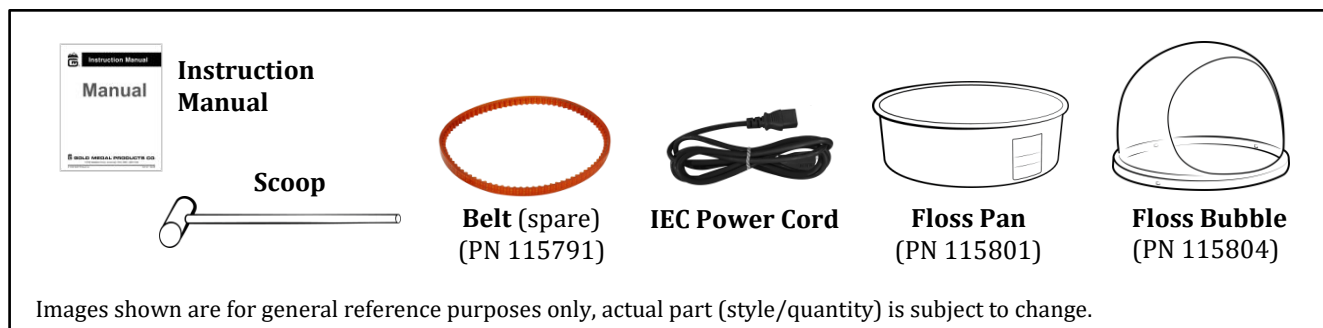

## Additional items needed for use (not included):

- Philips head screwdriver (for floss cap screws).
- Squirt water bottle (approx. 8 oz.); capable of squirting a steady stream (not a mist).



## Setup for Use

General images shown for reference purposes only.

1. Make sure Power Switch is OFF.  
Set unit on level surface; install pan.

Label goes on control side.

Interlock under latch.

2. Latch pan in (4) places.

Center head in pan.

Interlock **must be engaged** for unit to operate.

3. Make sure cap screws are tight.

4. Lock tab under rim at least 2 places.

5. Fully insert IEC Plug into unit.



6. Plug unit into a proper power source, reference Electrical Requirements section.

**Unit should be cleaned prior to use** (reference Care and Cleaning section of this manual).

## Electrical Requirements

The following power supply must be provided (reference unit Data Plate for Wattage requirement):

120 V~, 60 Hz  
220-230 V~, 50/60 Hz

	 <b>DANGER</b>
	<p>Machine must be properly grounded to prevent electrical shock to personnel. Failure to do so could result in serious injury, or death. Make sure all machine switches are in the OFF position before plugging the equipment into the receptacle. Keep cord and plug off the ground and away from moisture. Always unplug the equipment before cleaning or servicing. <b>DO NOT</b> immerse any part of this equipment in water. <b>DO NOT</b> use a water jet or excessive water when cleaning.</p> <p style="text-align: right; font-size: small;">008_012221</p>

A certified electrician must furnish sufficient power for proper machine operation and install any supplied receptacle (reference unit Data Plate for model specific Volts AC, Hertz, and Wattage requirements). We recommend this equipment be on a dedicated and protected circuit. Failure to wire properly will void the warranty and may result in damage to the machine. It is Gold Medal Products Co.'s recommendation that this machine be plugged directly into a wall outlet. The use of extension cords is not recommended due to safety concerns, and may cause sacrificed and/or reduced performance. Make sure cord is located to prevent a trip hazard or unit upset. Units with an IEC Power Cord - make sure the IEC cord is properly seated into the IEC receptacle before powering up the machine.

## Before You Plug In Machine

1. Make sure all machine switches are OFF before plugging equipment into receptacle.
2. Make sure wall outlet can accept the grounded plugs (where applicable) on the power supply cord.
3. The wall outlet must have the proper polarity. If in doubt, have a competent electrician inspect the outlet and correct if necessary.
4. **DO NOT** use a grounded to un-grounded receptacle adapter (where applicable).
5. Install unit in a level position.

	 <b>CAUTION</b>
	<p>If the supply cord is damaged, it must be replaced by a special cord or assembly available from Gold Medal Products Co. or its service agent.</p> <p style="text-align: right; font-size: small;">038_062714</p>

# OPERATING INSTRUCTIONS



## Controls and Their Functions

### MAIN POWER SWITCH



ON/OFF lighted rocker switch - supplies power to the control.

### HEAT MODE Switch (2 positions); HEAT STATUS Indicator Light



**Make Floss:** Controls the floss head motor and heating element.

-  **Blinking Green** **QuickStart** mode: Unit heating up to floss making temp. *Restarting from Standby, decreases reheat time by up to 50%.*
-  **Solid Green** **Ready** to make floss.

**Standby:** The control QuickCools the head, then maintains a low standby temp. for 1 hour.

-  **Blinking Red** **QuickCool** mode: Auto-cools cap and head (*motor spins 2 min., no heat*) to help prevent carbon buildup.
-  **Solid Red** **Standby** mode: Floss making paused (*no motor*); a low heat temp. is maintained for 1 hr. (*allows for a quick restart*).

### CONTROL STATUS Indicator Light

-  **Solid Yellow** **Power off** mode: 1 hr. Standby mode has expired, unit auto-shuts OFF. *Turn power OFF or toggle power OFF/ON to restart.*
-  **Blinking Yellow** Reference Troubleshooting section of this manual.

### INTERLOCK SWITCH

Safety switch to prevent machine operation without floss pan being locked down, reference Setup section of manual for proper pan installation.

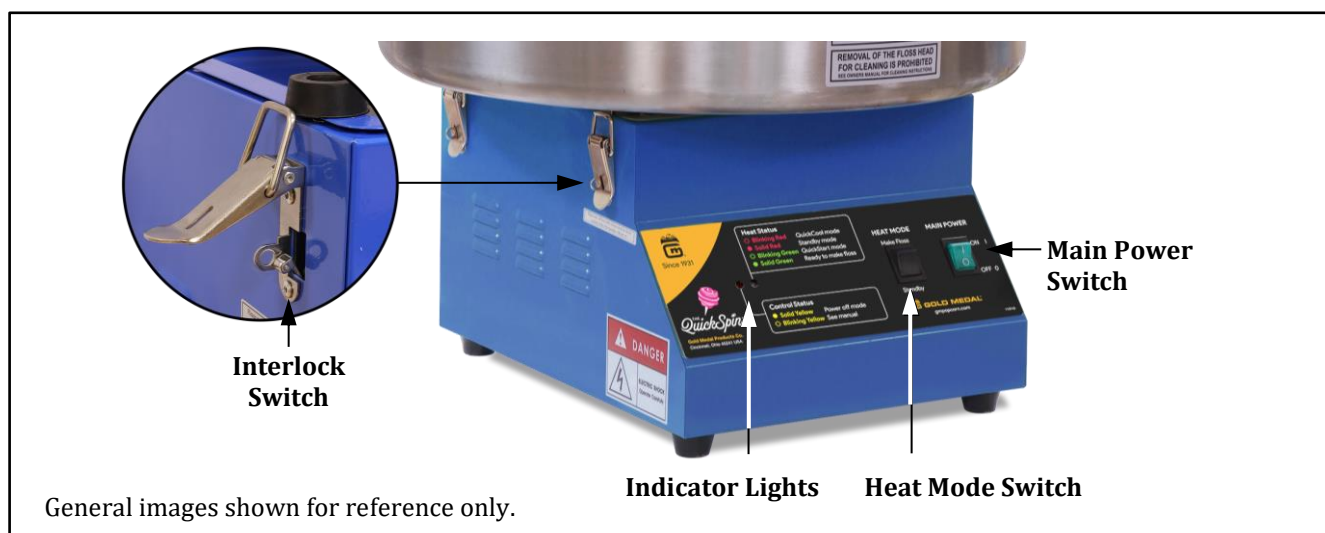



# Operating Instructions

For best results, use Gold Medal Flossugar in this machine (available in many flavors/colors). Images shown are for general reference only—see Setup section to prepare unit for operation.

## To Make Floss

Floss should float **upwards** to be gathered, for issues see Troubleshooting section.

1. Power ON (switch light is **green**).
2. Set Heat to **Make Floss** (QuickStart begins, LED blinking (**•••**) **green**).
3. LED turns solid (**—**) **green** (unit ready to make floss).
4. Fill scoop.
5. Pour into head.
6. Twist cone to gather floss.  
**To make another batch, add more sugar.**
7. Approx. every 20 batches, add 5–6 squirts of water.  
**CAUTION: Head is hot; water will steam and may spin out.**
8. To pause or power OFF the unit, **QuickCool the head**, see steps below.  
**CAUTION: Powering unit OFF without using QuickCool causes excessive burning in head and cap; unit damage can occur.**

## Standby Mode—QuickCool

Auto-cool head to **pause** floss making or to **turn unit OFF**.

1. Set Heat to **Standby**. QuickCool runs for **2 min**, LED blinking (**•••**) **red**.
2. While head spins, add 5–6 squirts of water to head.
3. After 2 min, LED solid (**—**) **red**. For solid (**—**) **yellow LED**, toggle power OFF/ON or turn unit OFF.



# Shut Down Procedure/ Care and Cleaning

	<b>⚠ DANGER</b>
<p>Machine must be properly grounded to prevent electrical shock to personnel. <b>DO NOT immerse in water.</b> DO NOT clean appliance with a water jet or steam cleaner. Always unplug the equipment before cleaning or servicing. 025_051321</p>	

	<b>⚠ WARNING</b>
<p>Burn Hazard. DO NOT touch spinner head. Allow to cool before cleaning or servicing. Avoid contact with molten sugar. 006_092414</p>	

Good sanitation practice demands that all food preparation equipment be cleaned regularly (only use non-toxic, food grade cleaners).

For any cleaning products used, follow the manufacturer’s instructions on the product. **DO NOT use oven cleaners or abrasive materials** as they will damage parts of machine.

## Shutdown and Clean Head

**CAUTION: Spinner head is hot.** Water used on a hot spinner head will steam and may spin out. Never touch hot spinner head, cap, or screws without using protective gear.

<p>1. Set Heat to <b>Standby</b>. <i>QuickCool runs for 2 min, LED blinking (•••) red.</i></p>	<p>2. While head spins, add 5–6 squirts of water to head.</p>	<p>3. After QuickCool (<i>head stops spinning</i>), turn Power Switch OFF.</p>	<p>4. <b>Loosen</b> cap screws. <b>Unit parts are hot;</b> never touch without using protective gear.</p>
<p>5. <b>Let head cool</b>, then remove cap and screws. <b>If cap sticks</b>, tap cap slightly to unstick.</p>	<p>6. Wash cap at sink.</p>		<p>7. <b>Clean threaded holes</b> (if needed). Slots help prevent sugar build-up in the holes; if needed, clean as follows:</p> <ol style="list-style-type: none"> <li><b>Briefly</b>, reheat head without cap.</li> <li>Turn unit OFF.</li> <li>Spray 1–2 squirts of water in <b>each</b> hole.</li> <li>Spin excess water out.</li> <li>Repeat as needed.</li> </ol>
	<p><b>Slotted Holes</b></p>		

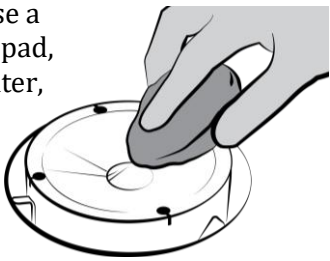
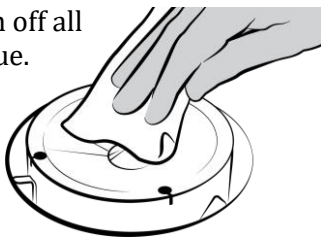

<p>8. After head cools, use a fine grit steel wool pad, dampened with water, to remove carbon.  (S.O.S.® type pad is acceptable.)</p>	<p>9. Wipe, to clean off all soap or residue.</p>
	
<p>10. When head is dry, reinstall cap and screws.</p>	

## Clean Unit Cabinet

1. Unplug the machine and wait for it to cool completely.
2. Remove the floss bubble and pan—take them to the sink to clean with a soft cloth, dish soap and water; then rinse and dry.
3. Wipe cabinet exterior clean with a soft cloth, SLIGHTLY dampened with soap and hot water, then wipe again to remove any remaining cleaner.

## Troubleshooting

**Troubleshooting** light conditions are shown below, for **general** Indicator Light descriptions, reference Controls and Their Functions section in the Operating Instructions.

Issue	Possible Cause	Solution
<p><b>No Power to the Unit</b> <i>(Power switch light is OFF; no indicator lights are on)</i></p>	<p>A. Unit not plugged in.</p> <p>B. Fuse blown (or possible switch issue).</p>	<p>A. Make sure the IEC cord is properly seated into the IEC receptacle; make sure unit is plugged into a proper power supply, see Electrical Requirements section.</p> <p>B. Have a qualified service person check for a blown fuse or switch issue, reference Maintenance section to access unit interior.</p>
<p><b>Power Switch is ON, but no indicator lights are ON.</b></p>	<p>A. Indicator light issue</p>	<p>A. Contact a qualified service person to inspect/repair the unit.</p>
<p><b>Low production</b></p>	<p>A. Low line voltage</p>	<p>A. The QuickSpin control is designed to provide constant power despite inconsistent wall voltage and extension cord use, but in extreme conditions check for low line voltage. Reference the Electrical Requirements section.</p>







Issue	Possible Cause	Solution
<p><b>Error Detection:</b> Indicator light is <b>Blinking Yellow</b> ☀️</p> <p><b>Two blinks</b> repeating</p> <p><b>Three blinks</b> repeating</p>	<p>A. Shorted triac error.</p> <p>B. Open triac error (or thermostat is open).</p>	<p>A. Control malfunction - unit is heating despite board current being turned off. Turn unit OFF; <b>do not</b> use the machine. Contact a qualified service person to inspect/repair the unit.</p> <p>B. Control malfunction – despite unit switches being ON for making floss, the board does not send current to the heater or motor. Turn unit OFF; <b>do not</b> use the machine. Contact a qualified service person to inspect/repair the unit.</p>
<p><b>Power Switch ON, but head not spinning.</b></p>	<p>A. Check indicator lights.</p> <p>B. Interlock switch.</p> <p>C. Broken (or loose) belt.</p> <p>D. Motor/capacitor issue.</p>	<p>A. ● <b>Solid Red</b> – unit in Standby mode (<i>minimal heat maintained for a quick restart; head does not spin</i>)—put Heat Mode switch in Make Floss position to restart.</p> <p>● <b>Solid Yellow</b> – unit in Power off mode (<i>unit auto-shuts off after 1 hour in Standby</i>); toggle Power switch OFF/ON to resume steps for unit operation or turn Power switch OFF.</p> <p>B. Unit will not operate without floss pan locked into place to engage the interlock switch. Reference Setup section for pan installation.</p> <p>C. When in Make Floss mode – if head is heating and <b>motor runs</b>, but head does not spin, the belt may be broken or loose. Contact a qualified service person to inspect/repair the unit.</p> <p>D. When in Make Floss mode - if head is heating, but <b>motor is not running</b>, the motor/capacitor may be the issue – contact a qualified service person to inspect/repair the unit.</p>
<p><b>Heat Mode switch is in Make Floss—head is spinning, but not heating properly.</b></p>	<p>A. Element issue or thermostat open</p>	<p>A. If indicator lights show normal (see Operating Instructions section), but head does not get hot enough to make floss, contact a qualified service person to inspect/repair the unit.</p>
<p><b>Floss not floating upwards.</b></p>	<p>A. Bent floss head winglets</p>	<p>A. <b>Check each winglet</b> for bent edges. The winglet surfaces should be straight, see below.</p> <div data-bbox="964 1520 1401 1766" data-label="Image"> </div> <p><b>Carefully</b> straighten the winglet. <b>DO NOT</b> use the unit if the winglet becomes loose or is missing, contact a qualified service person to inspect/repair the unit.</p>







—THE FOLLOWING SECTIONS ARE FOR QUALIFIED SERVICE PERSONNEL ONLY—

# MAINTENANCE INSTRUCTIONS

	 <b>DANGER</b>
	<p>Machine must be properly grounded to prevent electrical shock to personnel. Failure to do so could result in serious injury, or death. Make sure all machine switches are in the OFF position before plugging the equipment into the receptacle. Keep cord and plug off the ground and away from moisture. Always unplug the equipment before cleaning or servicing. DO NOT immerse any part of this equipment in water. DO NOT use a water jet or excessive water when cleaning.</p> <p style="text-align: right; font-size: small;">008_012221</p>

	 <b>DANGER</b>
	<p>Improper installation, adjustment, alteration, service, or maintenance can cause property damage, injury, or death. Any alterations to this equipment will void the warranty and may cause a dangerous condition. This appliance is not intended to be operated by means of an external timer or separate remote-control system. NEVER make alterations to this equipment. Read the Installation, Operating, and Maintenance Instructions thoroughly before installing, servicing, or operating this equipment.</p> <p style="text-align: right; font-size: small;">014_020416</p>

	 <b>WARNING</b>
	<p>No user serviceable parts inside. Refer servicing to qualified service personnel.</p> <p style="text-align: right; font-size: small;">011_051514</p>

	 <b>CAUTION</b>
	<p>THE FOLLOWING SECTIONS OF THIS MANUAL ARE INTENDED ONLY FOR QUALIFIED SERVICE PERSONNEL WHO ARE FAMILIAR WITH ELECTRICAL EQUIPMENT. THESE ARE NOT INTENDED FOR THE OPERATOR.</p> <p style="text-align: right; font-size: small;">027_010914</p>



# Parts Installation

Part installation or removal must be performed by qualified service personnel only. Unit must be OFF, unplugged and completely cool before beginning any service on this unit.

General images shown for reference purposes only. When servicing, reference wire diagram for unit.

## Remove/Install Top Cover

Remove top cover to access interior parts (save fasteners for reuse)—reinstall in reverse order.

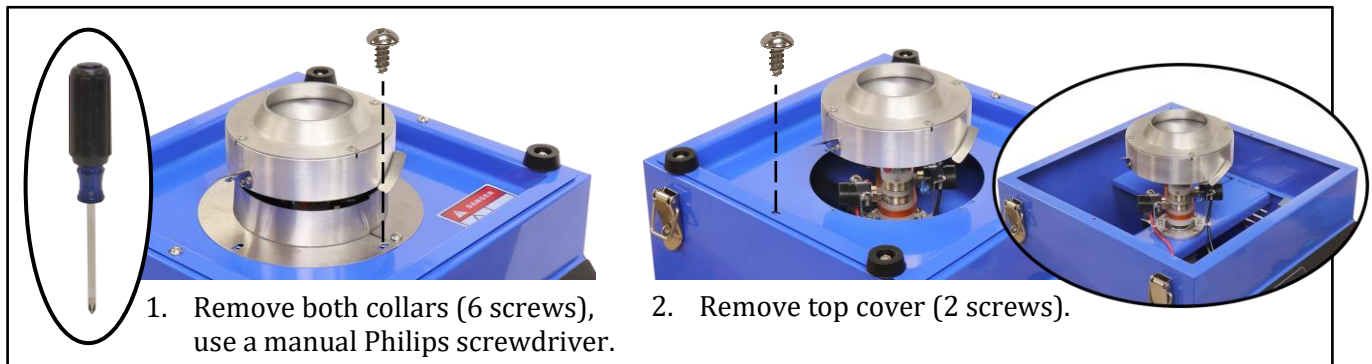

## Open/Close Control Panel – Access the Fuse

Instructions to open panel shown (save fasteners for reuse)—close panel in reverse order.

**IMPORTANT:** Always support the board when removing/connecting wires or board damage can occur.

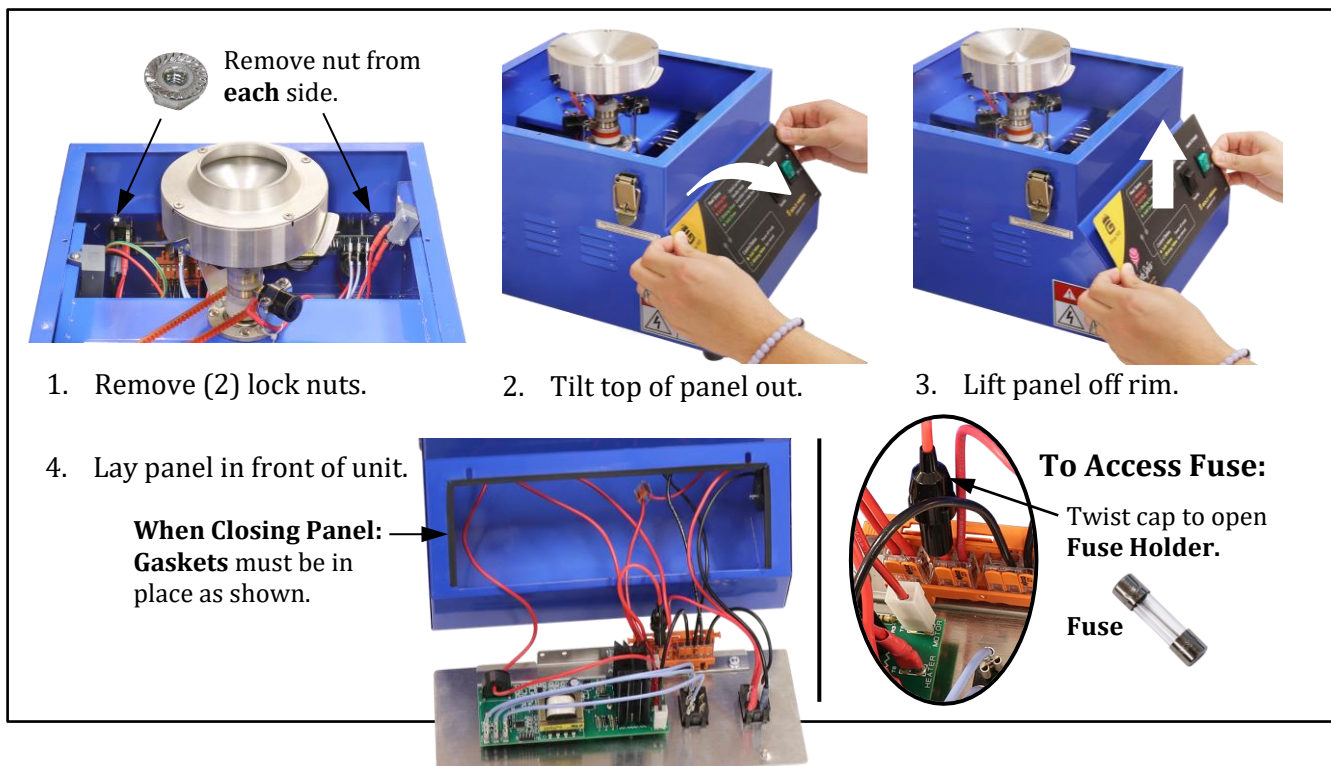





## Replace the Belt

Instructions shown are to remove belt for reuse (save fasteners for reuse)—replace or install a new belt in reverse order.

1. Remove the top cover (see Remove/Install Top Cover section).

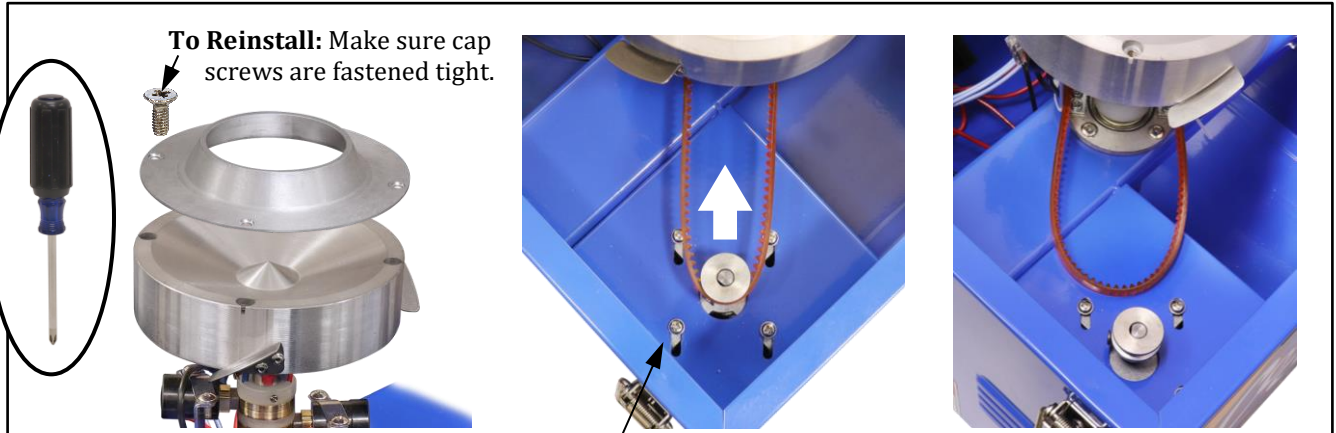

2. Remove cap (4 screws), use a manual Philips screwdriver.

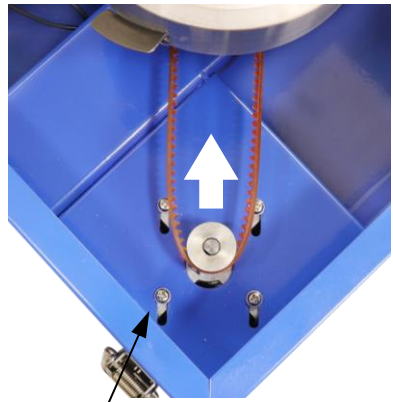

3. **Loosen** (4) motor screws, slide motor to loosen belt.

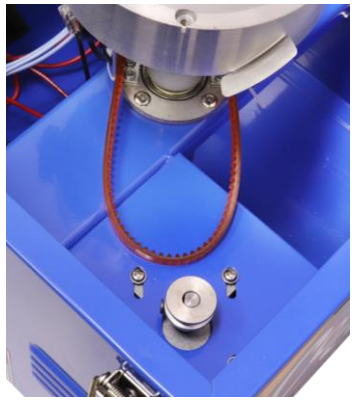

4. Slip belt off motor pulley.



5. Hold brush in with a flat head screwdriver. **Create a gap for belt.**

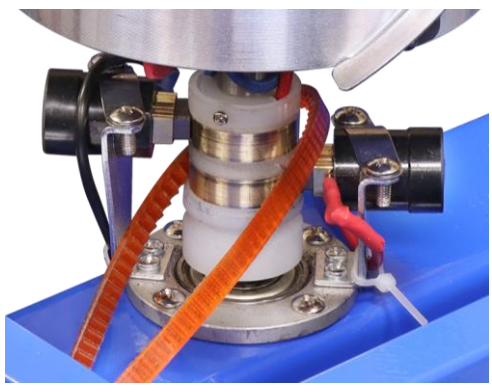

6. Move belt through gap until above brush.



7. Repeat steps for second brush, then remove belt over the head.

**Remember, when reinstalling:**

**Belt must be in groove on axes.**

**Pull to tighten belt, then refasten (4) motor screws.**



## Replace Motor/Capacitor

Instructions shown are to remove motor (save fasteners for reuse)—reinstall in reverse order.

1. Remove the top cover (see Remove/Install Top Cover section).
2. Open the front control panel (see Open/Close Control Panel section).

**Capacitor**

Disconnect **Neutral** from terminal block.

Remove **Red** from MOTOR pos. on board.

4. Remove screw holding capacitor.

5. **Loosen** (4) motor screws, slide motor to loosen belt.

3. Disconnect **(2) motor wires** from control panel—**support the board to remove/connect wires.**

6. Slip belt off motor pulley.

**To Reinstall:** Fasten pulley flush with top of shaft.

7. **Loosen** pulley screw, slide pulley off motor shaft.

8. **Support motor from falling**, then remove (4) motor screws.

9. Disconnect ground before lifting motor from cabinet. **Note motor orientation before removing.**

**Ground Screw**

**To Reinstall:** Refasten ground before mounting motor in cabinet.

**Motor and Capacitor**

10. See Replace the Belt section to properly reinstall the belt.



## Replace the Spinner Head and Axes

### Remove the Spinner Head (save fasteners for reuse):

**Important:** Removing the Spinner Head from the Axes can damage the parts (break wiring/connectors) see examples below. Gold Medal recommends replacing both items if separated—**damaged parts are not covered under warranty and must be replaced at your own expense.**

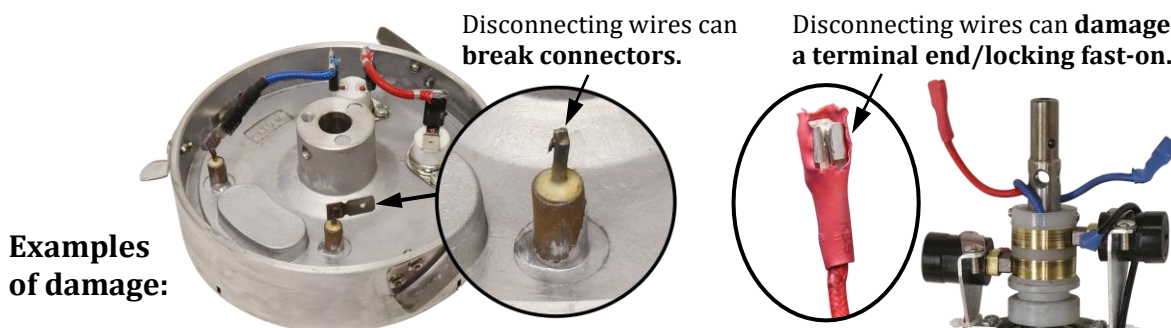

### To remove Spinner Head (read Important information above):

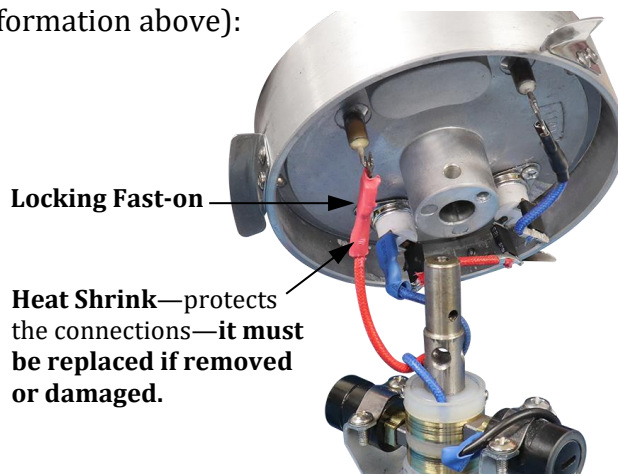
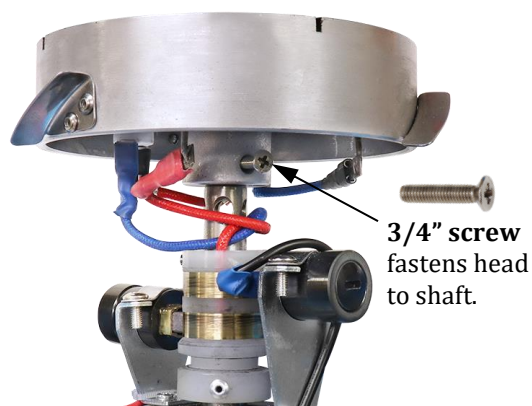

1. Remove the top cover (see Remove/Install Top Cover section).
2. Remove screw (save for reuse), see image.
3. Carefully lift head off shaft to access wiring.

4. Disconnect red and blue wires going to axes.

**IMPORTANT:** Each wire end has a **fast-on with a locking tab** on it—this tab must be released to disconnect the wire.

**DO NOT** use if connection(s) are damaged.

### Remove the Axes (save fasteners for reuse):

1. Remove the top cover (see Remove/Install Top Cover section).
2. Open the front control panel (see Open/Close Control Panel section) and disconnect the red wire and neutral wire coming from the heater (axes)—**support the board to remove/connect wires.**
3. Remove the belt (see Replace the Belt section).
4. Remove the (4) screws fastening the axes (reference Step 1 image below), then lift it out of the unit.



## Install a New Spinner Head and Axes

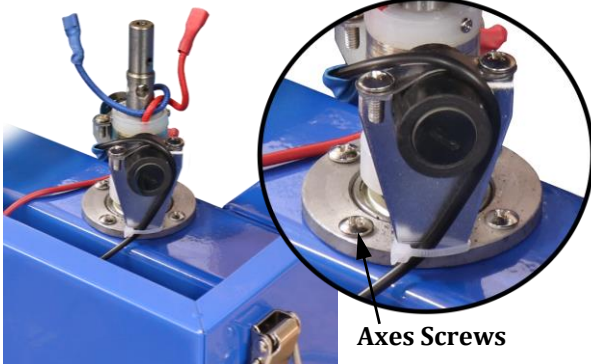

1. Install axes in cabinet, fasten with (4) screws.

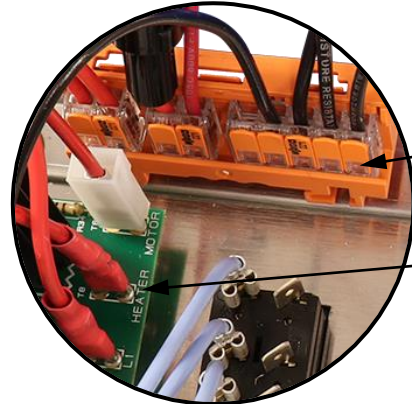

2. Connect (2) heater wires to control panel—**support the board** to remove/connect wires.

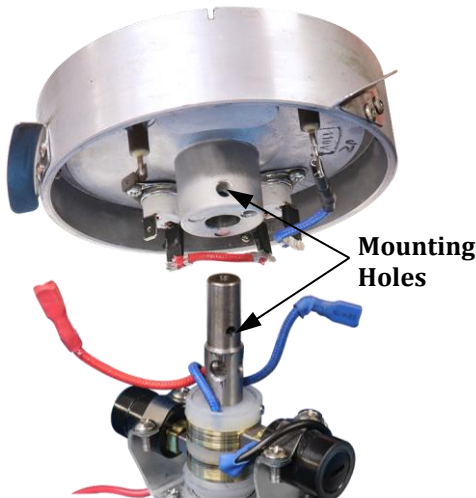

3. **Pre-align** mounting holes in head and shaft.

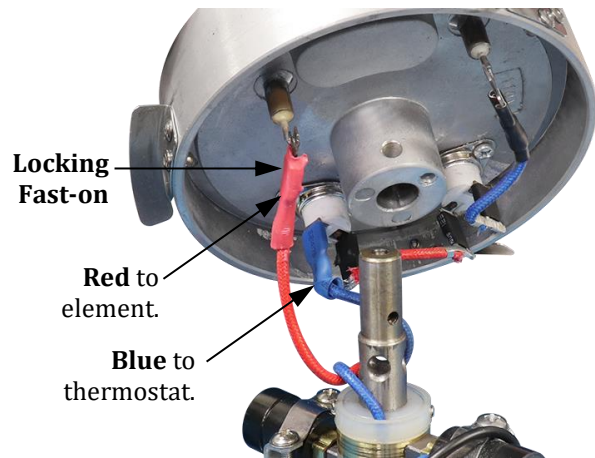

4. Wire axes to spinner head.

**IMPORTANT:** Each wire end has a **fast-on with a locking tab** on it—this tab must lock onto the connector when installed.

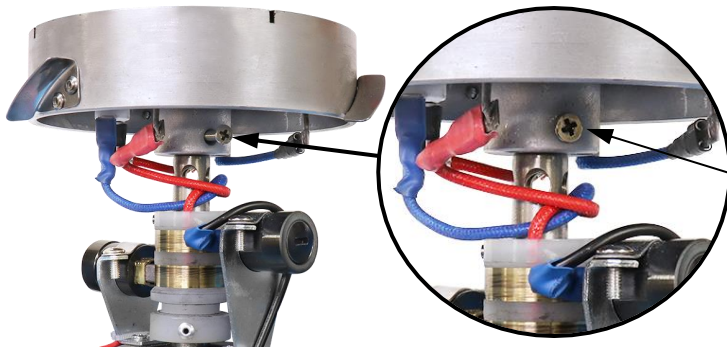

5. Slide head onto shaft, fasten with 3/4" screw (removed from old head).

6. Reassemble unit—see Replace the Belt section to properly reinstall the belt.



# ORDERING SPARE PARTS

1. Identify the needed part by checking it against the photos, illustrations, and/or parts list. (General images may be used in manual for reference only.)
2. Use only approved replacement parts when servicing this unit.
3. When ordering, please include part number, part name, and quantity needed.
4. Please include your model number, serial number, and date of manufacture (located on the machine nameplate/data plate) with your order.
5. Address all parts orders to Parts Department, Gold Medal Products Co., 10700 Medallion Drive, Cincinnati, Ohio 45241-4807

or place orders by phone or online:

Phone: (800) 543-0862  
(513) 769-7676

Fax: (800) 542-1496  
(513) 769-8500

E-mail: info@gmpopcorn.com  
Web Page: gmpopcorn.com

## Unit Exterior View

General images shown for reference only (actual part view may vary).



**CAUTION:** If supply cord is damaged, it must be replaced by a special cord or assembly available from Gold Medal Products Co. or its service agent.

Item	Part Description	Part Number	
		3001-00-000	3001-01-000
1	SSF-FLOSS BUBBLE-PACKED	115804	115804
2	SSF-STEEL FLOSS PAN	115801	115801
3	SSF-RUBBER FOOT	115794	115794
4	POWER CORD IEC	102020	
	POWER CORD IEC SCHUKO		42372



## Interior View

Reference the Maintenance section for instructions on accessing interior parts and for important replacement instructions.

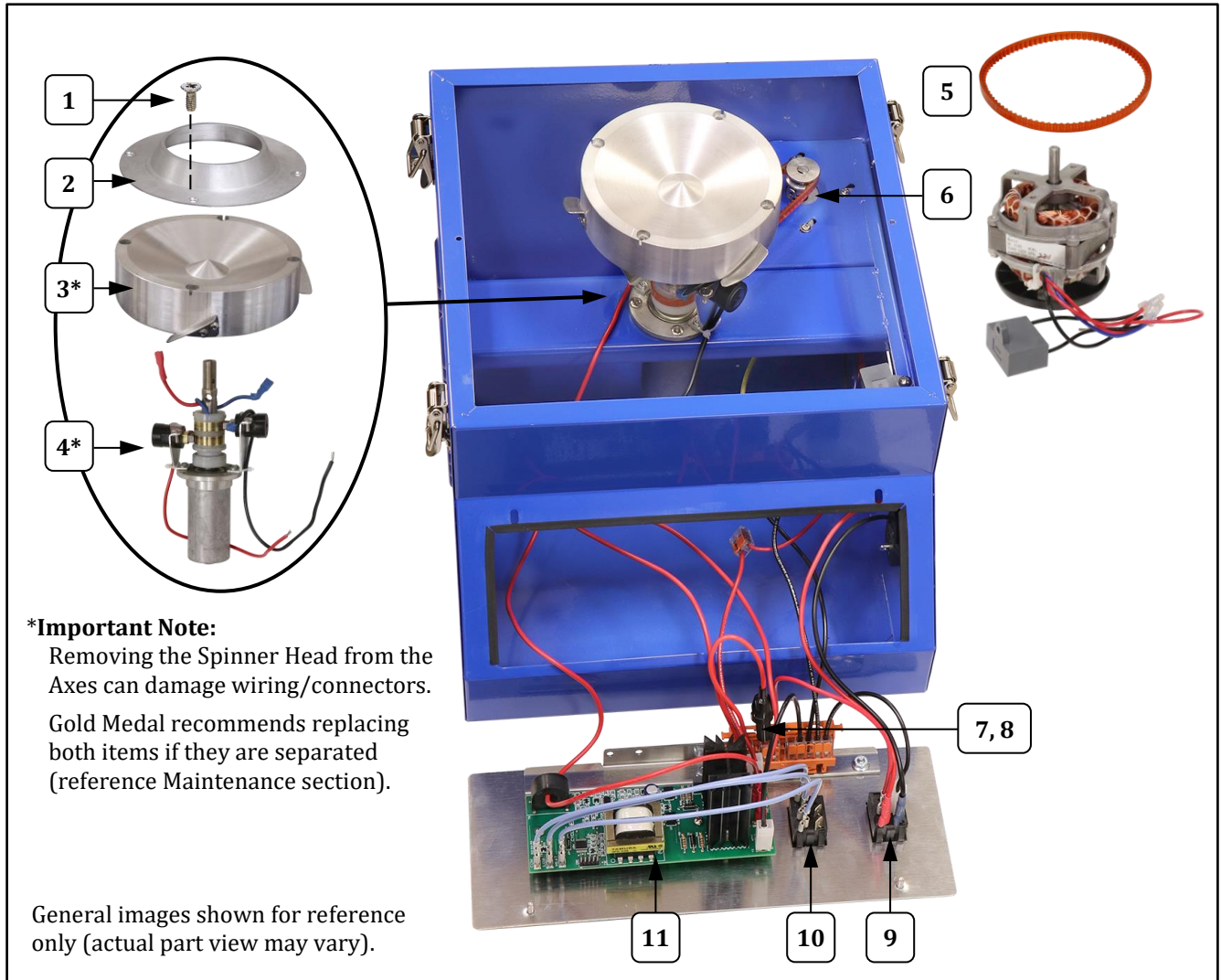

Item	Part Description	Part Number	
		3001-00-000	3001-01-000
1	M4X12 PH FHMS SS	115788	115788
2	SSF SPINNER CAP-MACH 5IN	115765	115765
3	SSF-SPINNER HEAD	115792	115793
4	SSF-AXES ASSEMBLY	115806	115806
5	SSF-MOTOR BELT	115791	115791
6	SSF-MOTOR	115795	115796
7	HOLDER, FUSE, 5 X 20 MM	112014	112014
8	FUSE, 15A	119240	119240
9	SWITCH, LIGHTED ROCKER GR	42798-30	42798-30
10	SWITCH, ROCKER DPDT GOLD	55440-30	55440-30
11	QUICK SPIN CONTROL BOARD	119237	119237



# Wiring Diagram

## Model No. 3001-00-000

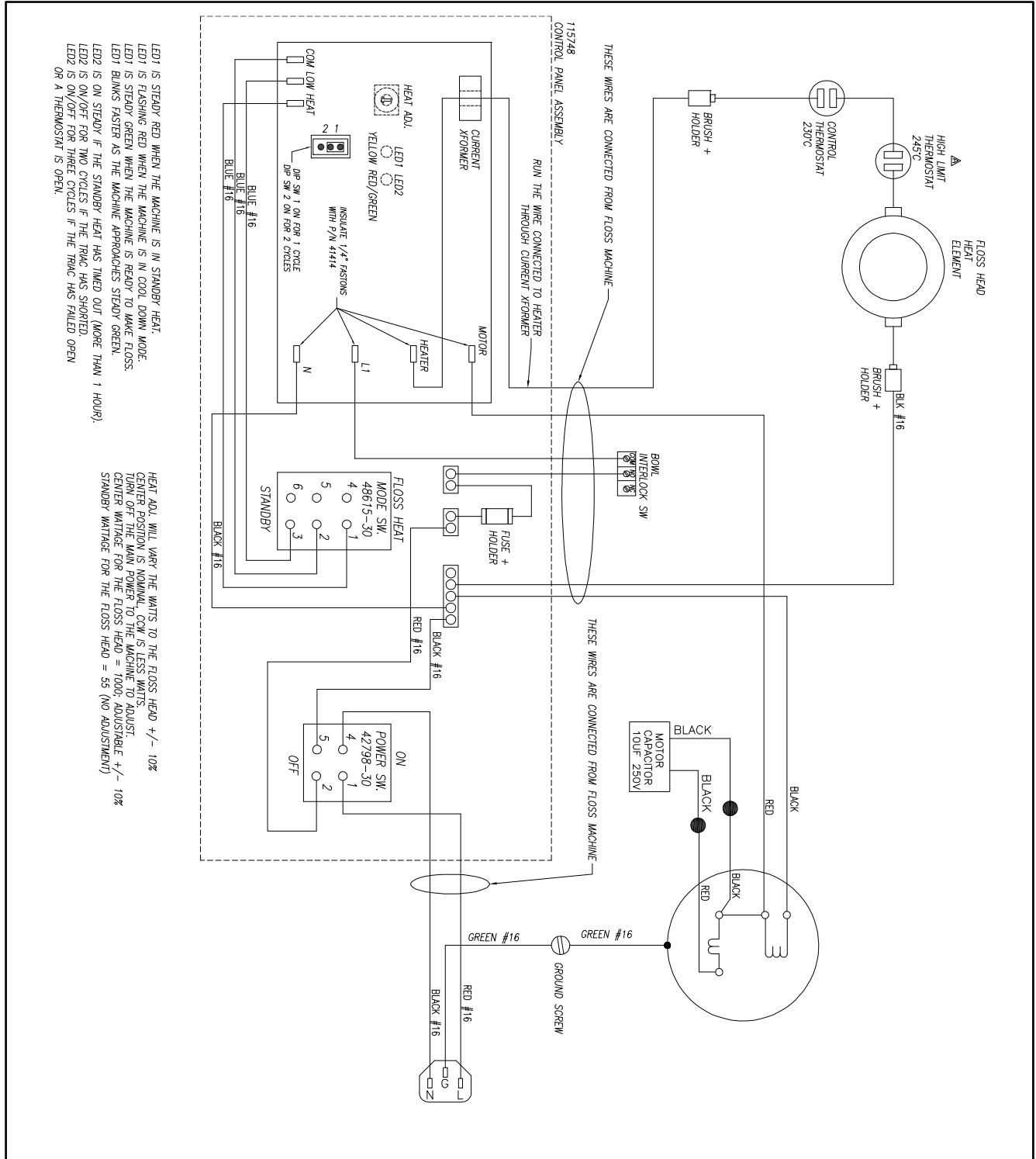







## The QuickSpin WARRANTY

Gold Medal Products Co. warrants to the original purchaser each item of its manufacture to be free of defects in workmanship and material under normal use and service. Gold Medal Products Co.'s obligation under this warranty is limited solely to repairing or replacing parts, f.o.b. Cincinnati, Ohio, which in its judgment are defective in workmanship or material and which are returned, freight prepaid, to its Cincinnati, Ohio factory or other designated point. Except for "Perishable Parts" on specific machines, the above warranty applies for a period of one (1) year from the date of original sale to the original purchaser of equipment when recommended operating instructions and maintenance procedures have been followed. These are packed with the machine. Parts warranty is one (1) year, labor is six (6) months.

THIS WARRANTY IS IN LIEU OF ALL OTHER WARRANTIES EXPRESSED OR IMPLIED, AND OF ALL OTHER OBLIGATIONS OR LIABILITIES ON OUR PART, INCLUDING THE IMPLIED WARRANTY OF MERCHANTABILITY. THERE ARE NO WARRANTIES WHICH EXTEND BEYOND THE DESCRIPTION ON THE FACE HEREOF. **THIS WARRANTY DOES NOT APPLY TO THE EQUIPMENT AND SERVICES RELATED TO THE NAYAX CASHLESS PAYMENT SYSTEM AND GOLD MEDAL EXPRESSLY DISCLAIMS ANY AND ALL WARRANTIES RELATED TO THE SAME.** In no event shall Gold Medal Products Co. be liable for special, incidental or consequential damages. No claim under this warranty will be honored if the equipment covered has been misused, neglected, damaged in transit, or has been tampered with or changed in any way. No claim under this warranty shall be honored in the event that components in the unit at the time of the claim were not supplied or approved by Gold Medal Products Co. This warranty is effective only when electrical items have been properly attached to city utility lines only at proper voltages. This warranty is not transferable without the written consent of Gold Medal Products Co.

The term "Original Purchaser" as used in this warranty shall be deemed to mean that person, firm, association, or corporation who was billed by the GOLD MEDAL PRODUCTS CO., or their authorized distributor for the equipment.

THIS WARRANTY HAS NO EFFECT AND IS VOID UNLESS THE ORIGINAL PURCHASER FIRST CALLS GOLD MEDAL PRODUCTS CO. AT 1-800-543-0862 TO DISCUSS WITH OUR SERVICE REPRESENTATIVE THE EQUIPMENT PROBLEM, AND, IF NECESSARY, FOR INSTRUCTIONS CONCERNING THE REPAIR OR REPLACEMENT OF PARTS.

*NOTE: This equipment is manufactured and sold for commercial use only.*



**GOLD MEDAL PRODUCTS CO.**

10700 Medallion Drive, Cincinnati, Ohio 45241-4807 USA

[gmpopcorn.com](http://gmpopcorn.com)

Phone: (800) 543-0862      Fax: (800) 542-1496  
(513) 769-7676              (513) 769-8500